



EKSELANS BY ITS

RACKS MURALES DE 19" 450MM FONDO R6 19 450 / R9 19 450 450MM DEPTH 19" WALL RACKS R6 19 450 / R9 19 450



Referencia	Reference		R6 19 450	R9 19 450
Código	Code		396001	396002
Apertura de la puerta	Door opening	°	180	
Paneles laterales	Lateral panels		2	
Entradas de cable	Cable inputs		2 (Superior e inferior Top & Bottom)	
Carga estática	Static load	Kg	60	
Vidrio templado	Tempered glass	mm	5	
Índice de protección	IP protection index		IP20	
Dimensiones (An. X Fo. X AL.)	Dimensions (WxDxH)	mm	(600 x 450 x 370) - 6U	(600 x 450 x 500) - 9U



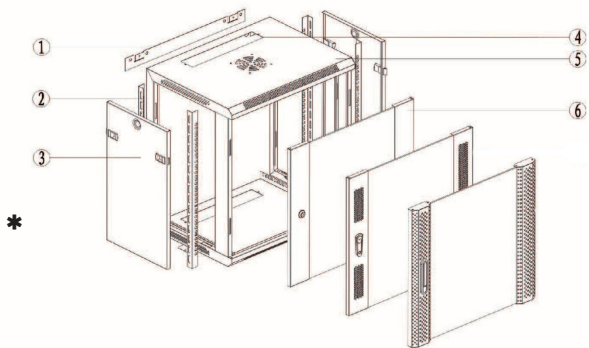

*

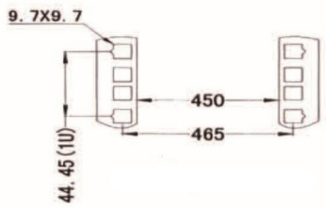
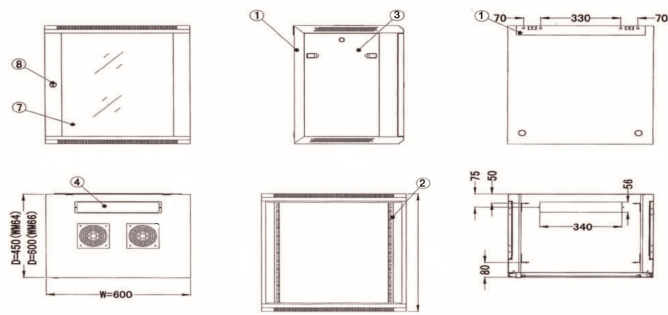

*

- 1.** [ES] Panel trasero
[EN] Back board

- 2.** [ES] Perfil de montaje (L)
[EN] Mounting profile (L-shaped)

- 3.** [ES] Panel lateral
[EN] Lateral side panel

- 4.** [ES] Pletina para entrada de cable
[EN] Cable entry plate

- 5.** [ES] Cuerpo
[EN] Main body

- 6.** [ES] Puerta con apertura 180°
[EN] 180° opening door

- 7.** [ES] Vidrio templado
[EN] Tempered glass

- 8.** [ES] Cerradura
[EN] Lock